

## Mounting base for hinged joints

### Technopolymer

#### BASE

Glass-fibre reinforced polyamide based (PA) technopolymer, RAL 9005 (C9) black colour or grey RAL 7040 (C33) colour, matte finish.

#### SCREW AND NUT (SUPPLIED)

Cylindrical-head screws with hexagon socket in AISI 304 stainless steel with anti-seizure treatment.  
Self-locking nut in AISI 304 stainless steel.

#### STANDARD EXECUTIONS

- **TCC-PBF-E**: external teeth.
- **TCC-PBF-S**: without teeth.

#### FEATURES

A base with external teeth can be joined to a clamp with internal teeth, or a base without teeth to a clamp without teeth, to create a hinged joint.

Joints comprising bases with external teeth and clamps with internal teeth (36 teeth) have a 10° adjustment angle.

Joints comprising bases and clamps without teeth can be positioned at any angle.

The "s" grub screw may be replaced by the kit TCC-KS.



ELESA Original design

#### TECHNICAL DATA

The resistance values shown in the table were measured during laboratory tests at ambient temperature with the screws tightened to the maximum torque "C#".

#### ACCESSORIES ON REQUEST (TO BE ORDERED SEPARATELY)

- TCC-KS (see page -): clamping kit.
- TCC-KV (see page -): screws and clamping nuts.

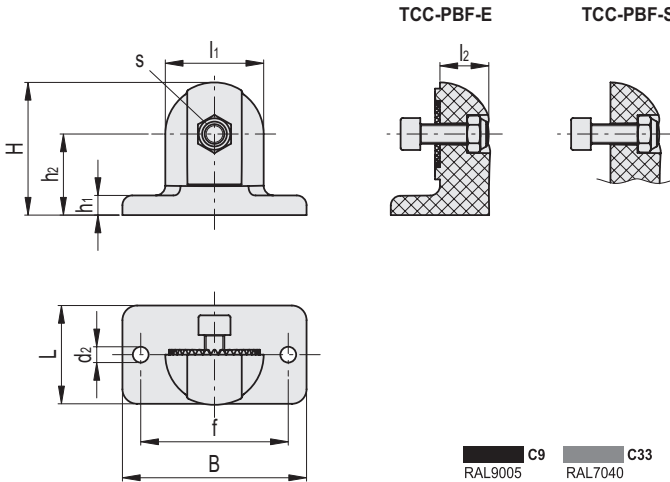

■ C9 RAL9005    ■ C33 RAL7040

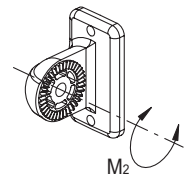

#### TCC-PBF-E

STAINLESS STEEL

Code	Description	L	B	H	d2	f ±0.2	h1	h2	l1	l2	s	C# [Nm]	M2*** [Nm]	⚖
600431-C9	TCC-PBF-30-E-C9	40	75	54	6.5	60	8	33	40	20	M8	12	100	63
600431-C33	TCC-PBF-30-E-C33	40	75	54	6.5	60	8	33	40	20	M8	12	100	63

#### TCC-PBF-S

STAINLESS STEEL

Code	Description	L	B	H	d2	f ±0.2	h1	h2	l1	l2	s	C# [Nm]	M2*** [Nm]	⚖
600435-C9	TCC-PBF-30-S-C9	40	75	54	6.5	60	8	33	40	20	M8	12	7	58
600435-C33	TCC-PBF-30-S-C9	40	75	54	6.5	60	8	33	40	20	M8	12	7	58

# Suggested torque for screw assembly.

\*\*\* Resistance to joint rotation.

1  
2  
3  
4  
5  
6  
7  
8  
9  
10  
11  
12  
13  
14  
15  
16  
17  
18  
19  
20

Tube connectors 16